

Contents

Simple parameter setting.....	2
1. Preface.....	3
1.1 Precautions for purchase:	3
1.2 Inverter nameplate description:	3
2. Product model and specification.....	4
2.1 Product model and specification:	4
2.2 Schematic diagram:.....	4
3. Wiring diagram and precautions for safe use.....	6
3.1 Installation location and environment:	6
3.2 Main circuit terminal description:	6
3.3 Control terminal description:	7
4. Digital operator description.....	8
4.1 Description of digital operator panel:	8
4.2 Operation example:	8
5. Trial run.....	9
5.1 Inspection and trial operation method before operation:	9
6. Control function and parameter setting.....	10
6.1 Panel control wiring and parameter setting:.....	10
6.2 Three-wire control wiring and parameter setting:.....	10
6.3 High, medium and low multi-speed control wiring and parameter setting.....	11
6.4 Analog quantity control wiring and parameter setting:.....	11
6.5 External potentiometer with switch control wiring and parameter setting:.....	12
7. Function description and list.....	14
7.1 Function table:	14
8. Fault information and troubleshooting methods.....	26
8.1 Fault information and troubleshooting methods:.....	26
9. Modbus holding register address-inverter parameter correspondence table.....	28
10. External terminal two or three wire control motor wiring.....	32
11. Multi-speed command-frequency section-parameter item correspondence table.....	33
12. Toggle switch configuration table.....	33
13. Facilities selection configuration.....	33
13.1 Braking resistor configuration:.....	33
14. Customer feedback suggestions.....	35

Due to the company's product updates, the content is subject to change without notice

Simple parameter setting

Parameter number	name	Setting range and its meaning	Motor rated frequency Ordinary three-phase asynchronous motor	Motor rated frequency High-speed spindle	Motor rated frequency Ordinary three-phase asynchronous motor
P00.00	Main digital frequency	0-120HZ(400HZ)	50.0HZ	400.0HZ	60.0HZ
P00.04	VF curve: maximum output frequency	1.0-120.0HZ(400HZ)	50.0HZ	400.0HZ	60.0HZ
P00.05	VF curve: output frequency at maximum voltage	5.0-120.0HZ(400HZ)	50.0HZ	400.0HZ	60.0HZ
P00.07	VF curve: intermediate frequency	1.0-120.0HZ(400HZ)	5.0Hz	40.0Hz	6.0Hz
P00.08	VF curve: intermediate voltage	10.0%-100.0%	10%	10%	10%
P00.09	VF curve: minimum output frequency	0-120.0HZ(400HZ)	0.5Hz	4.0Hz	0.6Hz
P00.10	VF curve: minimum output voltage	0%-100.0%	1%	1%	1%
P00.13	Parameter recovery/locking/read and write	0: Allow users to set parameters	0		
		1: Forbid users to set parameters (locked)			
		10: Restore factory parameters (Need to power off, power on again)			
P03.09	Panel potentiometer, the upper limit of frequency setting	0-120HZ(400HZ)	50.0HZ	400Hz	60Hz
P03.13	Analog input 1, the upper limit of frequency setting(VI1--0-10V)	0.0-400.0HZ,See "JP1 Short Circuit Block Configuration Table"	50.0HZ	400.0HZ	60.0HZ
P12.19	PWM frequency	2.0-15.0KHZ	110V10.0KHz-----220V8.0KHz		

Note: If you need to restore the factory settings, set P00.13 to 10, press the confirm key, then turn off the power supply and wait for the inverter lights to go out before powering on, otherwise the restoration will be unsuccessful.

If you need to modify the parameters, you must set the inverter in a non-working state (such as the RUN light is off). After the setting is completed, you must turn off the power and turn off the inverter lights before powering on, otherwise the setting will be unsuccessful.

1. Preface

1.1 Precautions for purchase :

This machine is strictly packaged before leaving the factory, but considering various factors during transportation, please pay special attention to the following matters before assembling. If there is any abnormality, please notify the distributor or related personnel of the company.

- Whether it is damaged or deformed during transportation.
- Is there a YL series inverter and a manual when the package is unpacked?
- Whether the ordered specifications are consistent with the nameplate (Working voltage and KVA number).
- Whether the internal assembly parts, wiring and circuit board are abnormal.
- All terminals are locked tightly, and there is no foreign matter in the machine.
- Whether the buttons of the operator are normal.
- Are there additional accessories.

1.2 Inverter nameplate description :

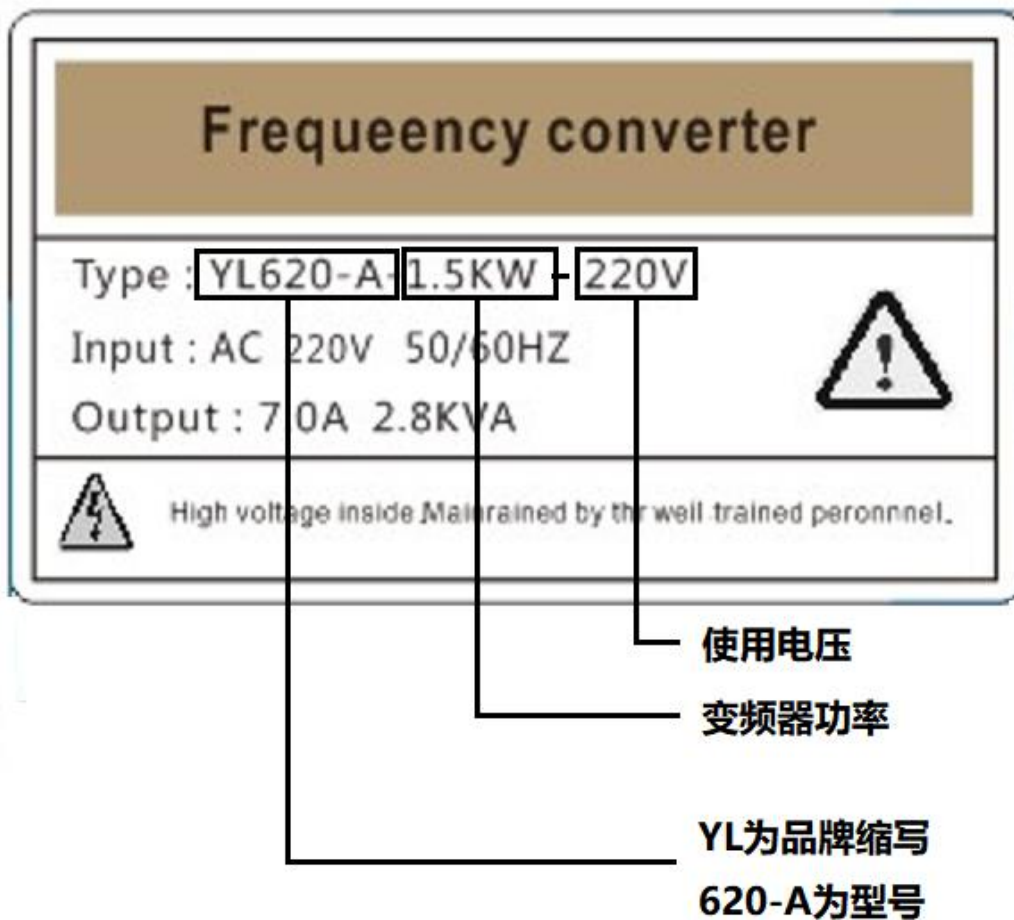

使用电压： Working Voltage

变频器功率： Inverter power

YL： Brand abbreviation

型号： model

2. Product model and specification

2.1 Product model and specification:

Model	Input voltage	power (KW)	Drive capacity (KVA)	Output current (A)	Applicable motor (KW)
YL620/YL620-A	single-phase 110V 60Hz	0.75	4	7.8	≤ 0.75KW
YL620/YL620-A	single-phase 110V 60Hz	1.5	6	13	≤ 1.5KW
YL620/YL620-A	single-phase 110V 60Hz	2.2	8	21	≤ 2.2KW
YL620/YL620-A	single-phase 220V 50/60Hz	0.75	2.4	4	≤ 0.75KW
YL620/YL620-A	single-phase 220V 50/60Hz	1.5	3.0	7	≤ 1.5KW
YL620/YL620-A	single-phase 220V 50/60Hz	2.2	4.0	10	≤ 2.2KW

2.2 Schematic diagram:

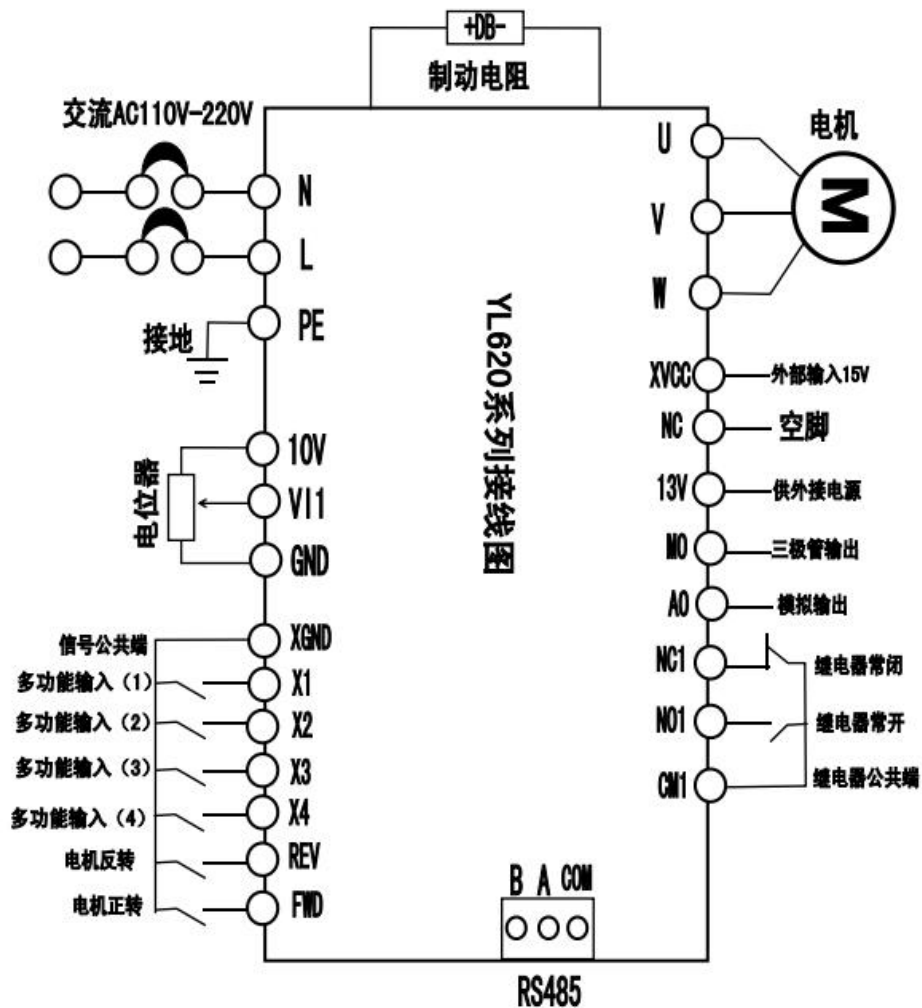

制动电阻: Braking resistor (+DB-)

交流: AC(110V/220V)

接地: protecting earthing (缩写 PE)
电位器: Potentiometer(10V VI1 GND)
信号公共端: Signal common terminal(XGND)
多功能输入: Multi-function input(X1 X2 X3 X4)
电机反转: Motor reverse(REV)
电机正转: Motor forward(FWD)
YL620 系列接线图: YL620 series wiring diagram
电机: The motor (M)
外部输入 15V: External input 15V(XVCC)
空脚: NC
供外接电源: External power supply(13V)
三极管输出: Triode output(MO)
继电器常闭: Relay normally closed(NC1)
继电器常开: Relay normally open(NO1)
继电器公共端: Relay common terminal(CM1)

3. Wiring diagram and precautions for safe use

3.1 Installation location and environment :

- Ambient temperature: -5°C~40°C and good ventilation;
- Places with no dripping water and low humidity;
- Places without sunlight, high temperature and severe dust;
- Location without corrosive gas and liquid;
- Places with less dust, oil gas and metal dust;
- No vibration, easy maintenance and inspection place;
- Places without electromagnetic noise interference;
- In order to facilitate cooling and maintenance, sufficient space must be left around the inverter.
- In order to achieve a good cooling effect, the inverter must be installed vertically and ensure smooth air circulation.
- If the installation is not secure, place a flat plate under the base of the inverter before installing. If installed on a loose surface, the stress may cause damage to the main circuit parts, thus damaging the inverter;
- The installation wall should use non-combustible materials such as iron plates.
- When multiple inverters are installed in the same cabinet, pay attention to the spacing when installing them up and down, and add a baffle plate in the middle.
- Be sure to correctly connect the inverter main circuit and control signal wires.
- Be sure to set the inverter parameters correctly.

Note: Power supply: Please pay attention to whether the voltage levels are consistent to avoid damage to the inverter.
The environment of the installation site will affect the service life of the inverter.

3.2 Main circuit terminal description :

Terminal symbol	Description
N L	Power input terminal (220V inverter is single-phase 220V input, 110V inverter is single-phase 110V input)
U.V.W	Inverter output terminal (220V inverter is three-phase 220V output, 110V inverter is three-phase 110V output)
+ DB -	Braking resistor connection end optional (see page 27 for details on braking resistor configuration)
FG	Frame Ground 

3.3 Control terminal description:

Terminal symbol	Description	Factory setting
NC	NOTCONNECTED	
MO	Triode output	
FWD	Forward	
REV	Reverse	
X4	Multi-function input 4	
X3	Multi-function input 3	
X2	Multi-function input 2	
X1	Multi-function input 1	
XGND	Common terminal of digital control signal	
XVCC	External input 15V	
GND	Analog control signal common terminal	
VI1	Analog current frequency command	
10V	Power supply for speed setting	
13V	External power supply	
AO	Analog output	
NC1	Relay normally closed contact	
NO1	Relay normally open contact	
CM1	Relay common terminal	

4. Digital operator description

4.1 Description of digital operator panel:



数字显示器: Digital display

正/反转切换键: Forward/reverse switch key

运行键: Run key

停止复位键: Stop reset button

移位键: Shift key

频率调节键: Frequency adjustment key

编程键 (进/退): Programming key (forward/backward)

选择/确认键: Select/confirm key

递增递减键: Up and down keys

4.2 Operation example:

Upload the inverter host parameters to the digital operator:

Press the (stop) **STOP** button and not release it, and then press the (up arrow) **▲** button, the digital operator will automatically read all the parameters in the inverter host and save them in the digital operator, and the original parameters will be overwritten. The digital operator can only save the last parameter uploaded. After uploading is complete, please press (program) **PRGM** key to exit. During the upload process, if there is an error, its error number will be displayed. Please press the (program) **PRGM** button to clear the error and try the above upload operation again.

Download the parameters in the digital operator to the inverter host:

Press the (stop) **STOP** button and not release it, and then press the (down arrow) **▼** button, the digital operator will automatically download all the parameters in the digital operator to the inverter host, and save it in the inverter host. The original parameters are overwritten. The inverter host can only save the last downloaded parameter. After the digital operator downloads the parameters, the parameters of the digital operator remain unchanged. After downloading is complete, please

press (program) **PRGM** key to exit. During the download process, if there is an error, its error number will be displayed. Please press (program) **PRGM** to clear the error, and try the above download operation again.

Inverter cooling fan trial run:

Each time you press (stop) the **STOP** button, the cooling fan will be forced to run for about 30 seconds to facilitate the user to observe the working status of the fan.

Parameter setting method:

1. Press the (programming) **PRGM** key until the inverter displays "Pyy.xx" to enter the parameter setting state. Where yy represents the parameter group number, and xx represents the parameter number. For example, P01.12 indicates the 12th parameter of the 01 group (for the specific meaning of each parameter, please refer to the parameter description table).
2. Press (plus or minus arrow) **▲▼** key to select the parameter group number and parameter number to be set. Press (data function) **SET** key to enter the parameter value setting state, the display is 60.0; press (plus and minus arrow) **▲▼** keys to modify the parameter value; at this time, press (data function) **SET** key to save the currently modified parameter value. You can also press the (programming) **PRGM** key to exit the parameter setting state and abandon the modification of the parameters.

When selecting the parameter group number and parameter number, you can press the (shift) **DISP** key to select the parameter group number and parameter number (flashing display) to quickly select the parameter that the user is interested in. Similarly, when modifying the parameter value, you can press the (shift) **DISP** key to select the digit of the parameter to be modified (flashing display), so as to quickly modify the parameter value.

After modifying the parameters, press the (program) **PRGM** key to exit the parameter setting state.

Note that if the parameter table is locked (P00.13=1), all parameters can only be viewed but cannot be modified. Please set its parameters when the inverter is stopped. When the inverter is running, the parameters you set can actually be effective, but can only be saved after the inverter stops.

5. Trial run

5.1 Inspection and trial operation method before operation:

- Is there a wiring error? In particular, check whether the power supply is incorrectly connected to the U.V.W terminal; please note: the power supply should be input from the N\L terminal.
- Whether there are any metal chips or wires remaining on the inverter substrate and wiring terminals that may cause short circuits;
- Are the screws tightly locked and the connectors loose?
- Whether the output part has a short circuit or ground fault.

6. Control function and parameter setting

6.1 Panel control wiring and parameter setting:



适用型号 (Apply VFD) :
 → YL620-0.75KW/1.5KW/2.2KW-110V/220V
 → YL620-A-0.75KW/1.5KW/2.2KW-110V/220V

电压220V是指单相220V输入，三相220V输出，接普通三相异步电动机，电动机由380V（星型接法）改为220V（三角形接法），变频器不能接在单相带电容电动机上。
 220V means: Single-phase 220V the input. Three-phase 220V the output. The ordinary three-phase asynchronous motor. Motor 380V (Star) modified to 220V (Delta connection). VFD can't connect single phase motor

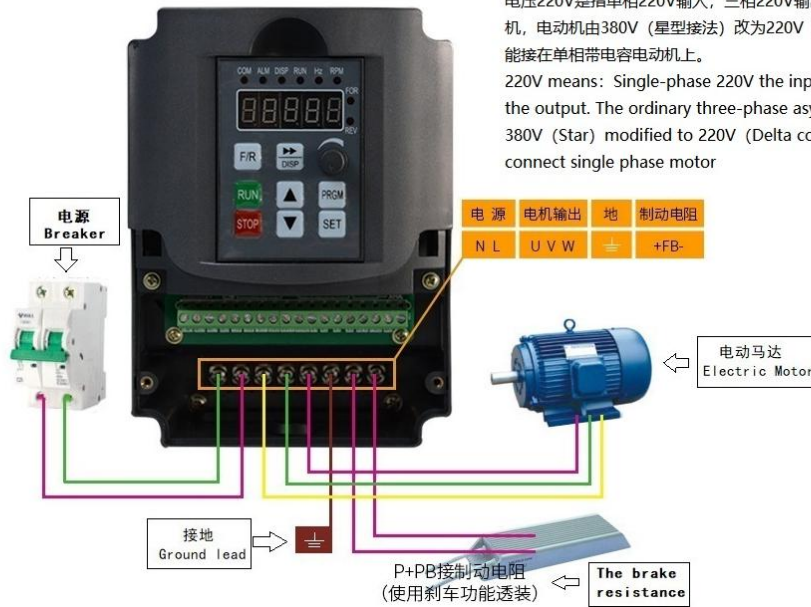

6.2 Three-wire control wiring and parameter setting:

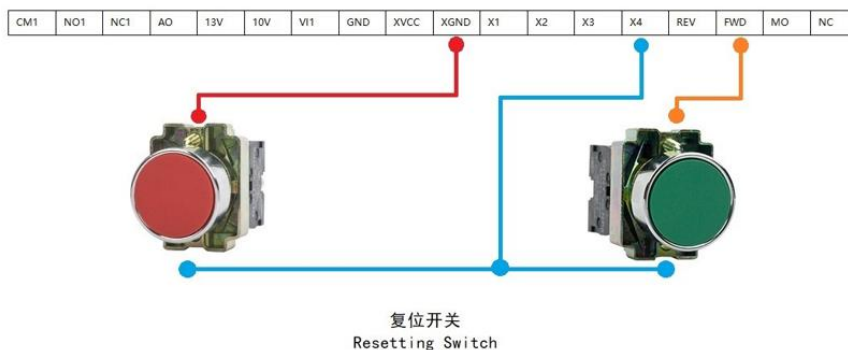

P00.01 设置为1 P00.16 设置为2
 备注：变频器在运行中不允许修改参数，设置无效。
 P00.01 Set up the 1 P00.16 Set up the 2
 Remark: VFD run, Do not modify the parameters.

6.3 High, medium and low multi-speed control wiring and parameter setting

通用型号: YL620-0.75KW-110V/220V
 YL620-1.5KW-110V/220V
 YL620-2.2KW-110V/220V
 YL620-A-0.75KW-110V/220V
 YL620-A-1.5KW-110V/220V
 YL620-A-2.2KW-110V/220V

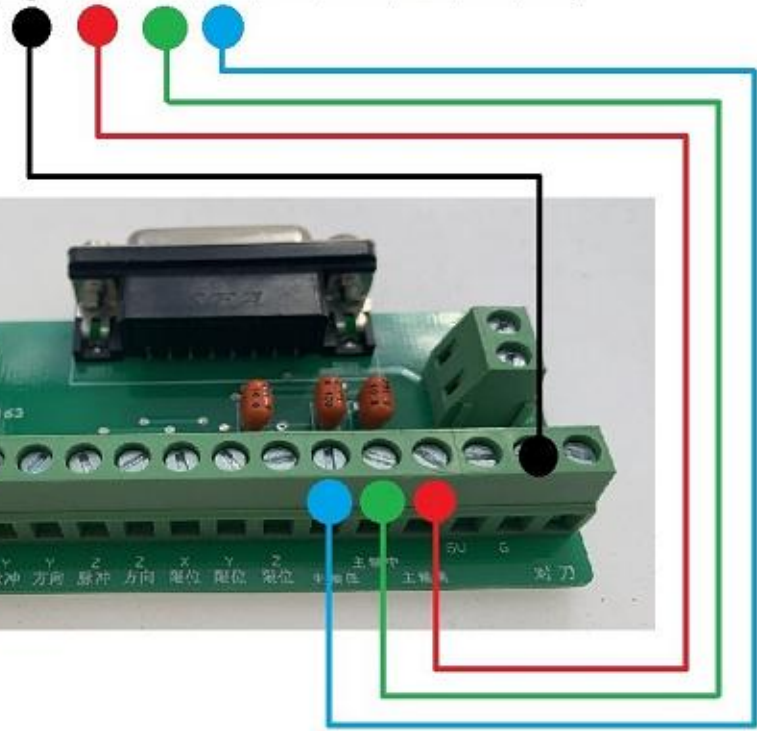

雕刻机准卡参数设置方式参考表: (搭配400HZ 24000转主轴电机)

P00.00	设置为400
P00.01	设置为1
P00.04	设置为400
P00.05	设置为400
P00.07	设置为40
P00.08	设置为10
P00.09	设置为4
P00.10	设置为1
P07.00	设置为0
P07.01	设置为100
P07.02	设置为150
P07.03	设置为200
P07.04	设置为250
P07.05	设置为300
P07.06	设置为350
P07.07	设置为400
P07.08	设置为2

频率参数需根据该雕刻机搭配不同频率的主轴来调整, 具体可联系客服。

必须变频器参数设置完成, 关机重启确保参数设置成功后, 再连接控制端线路。

6.4 Analog quantity control wiring and parameter setting:

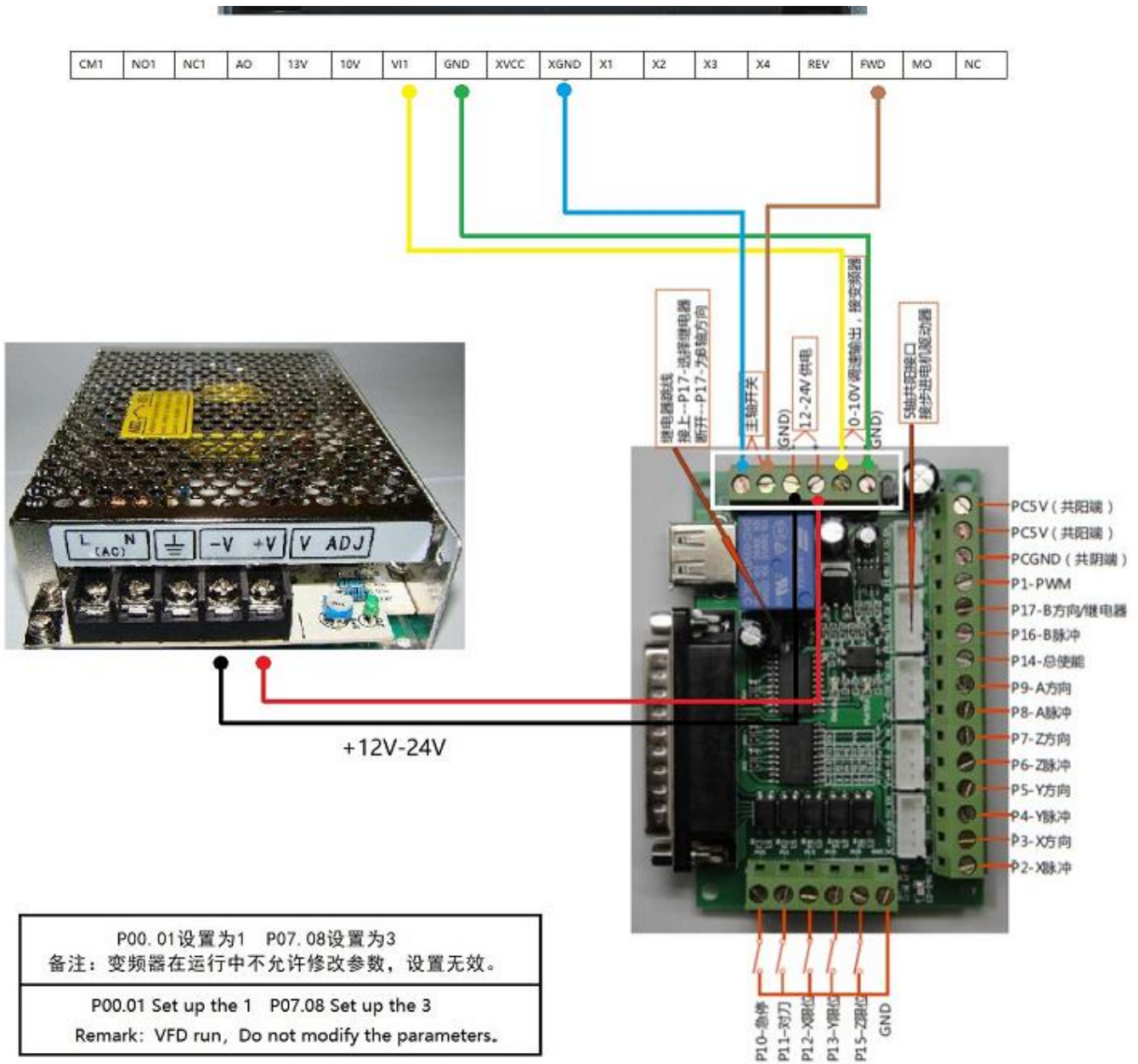

6.5 External potentiometer with switch control wiring and parameter setting:

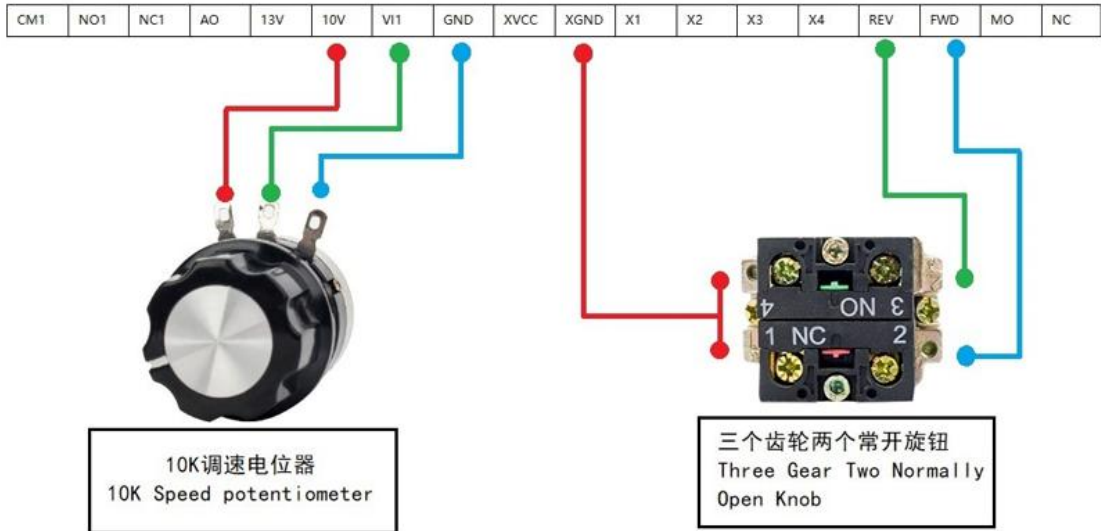

<p>P00.01设置为1 P07.08设置为3 备注：变频器在运行中不允许修改参数，设置无效。</p>
<p>P00.01 Set up the 1 P07.08 Set up the 3 Remark: VFD run, Do not modify the parameters.</p>



- | |
|--|
| <p>1、(1, 2) 向上 [upward]
(3, 4) 向下 [down] 为0-10V
2、(1, 2, 3, 4) 全部向下 [All down] 为0-5V</p> |
|--|

7. Function description and list

7.1 Function table:

YL620-A Inverter parameter table			
Parameter number	name	Setting range and its meaning	Factory default
P00.00	Main frequency	0.0-600.0HZ	400.0HZ
P00.01	Start/stop command source	0: Operate the motor by the operation panel	0
		1: The motor is controlled by the external terminal, and the STOP button on the operation panel is effective	
		2: The motor is operated by the external terminal, and the STOP button on the operation panel is invalid	
		3: Motor controlled by Modbus Rs485	
P00.02	Reserved		0
P00.03	Motor stop mode	0: Decelerate to stop	0
		1: Free stop (deceleration time is invalid)	
		2: Immediate DC braking to stop (the deceleration time is invalid)	
P00.04	VF curve-maximum output frequency	1.0-600.0HZ	400.0HZ
P00.05	VF curve-output frequency at maximum voltage	5.0.0-600.0HZ	400.0HZ
P00.06	VF curve-maximum output voltage	10.0%-150.0%	100.0%
P00.07	VF curve-intermediate frequency	1.0-600.0HZ	40.0HZ
P00.08	VF curve-intermediate voltage	10.0%-100.0%	10%
P00.09	VF curve-minimum output frequency	0.0-600.0HZ	4.0HZ
P00.10	VF curve-minimum output voltage	0%-100.0%	1%
P00.11	Use analog input 1 to control multi-speed	0%-100%	100
P00.12	VF curve style selection	0-4	0
P00.13	Parameter recovery/locking/read and write	0: Allow users to set parameters	0
		1: Forbid users to set parameters (locked)	
		10: Restore factory parameters (need to power off, power on again)	
		Other values: not available	
P00.14	Reserved		0
P00.15	Disable external terminal	0: When powering on, allow the existing effective level	1

	start when power on	of the external terminal to start the motor operation 1: When powering on, the existing effective level of the external terminals is not allowed to start the motor. In other words, after power-on, the effective level input on the external terminal can start the motor operation.	
P00.16	External terminal start/stop control mode selection	0: FWD (X5) is a forward running command, REV (X4) is a reverse running command 1: REV (X4) determines the direction: open for forward rotation, closed for reverse rotation; FWD (X5) is the start command: open to stop, closed to run 2: EF(X3), REV(X4), FWD(X5, self-holding). Three-wire control motor operation (reference: LK380 wiring diagram) 3: When stopping, FWD (X5) closes and starts the motor forward; when running, REV (X4) closes and stops instantly When stopping, REV (X4) closes and starts the motor reversely; when running, FWD (X5) closes and stops instantly "" 4: FWD (X5) starts the motor forward at the moment of closing action; REV (X4) stops at the moment of closing action 5: FWD (X5) starts the motor forward at the moment of closing action; REV (X4) stops at the moment of opening action 6: When stopping, the FWD (X5) closing action instantly starts the motor forward; when running, the FWD (X5) closing action instantly stops. When running, the REV (X4) closing action instantly reverses the motor direction. 7: When REV (X4) is open, FWD (X5) closes and starts the motor in the forward direction; when REV (X4) is closed, it is forbidden to start the motor; when REV (X4) closes, it stops instantly. 8: Wire cutting left and right limit commutation mode (X3 function should be set to "reserved", that is, P00.19=0. Refer to "wire cutting left and right limit commutation mode wiring diagram"). When START (X5) is open, stop. When START is closed, the direction is determined according to the	0

		<p>current state of the limit switch, and the motor is started. When START is closed, if the state of the two limit switches are both open, the default is to the left Start the motor. During running to the left, when the left limit switch (X_LSL, namely X3) is closed (limit), it changes to running to the right. During running to the right, when the right limit switch (X_LSR, namely X4) is closed (limit), it changes to running to the left. If the left and right limits are at the same time, the machine will stop; Note: Multi-function relay 1</p> <p>The function (P04.03) is selected as 17 (powered at constant speed, otherwise power is lost), and P04.05 and P04.06 are set to realize the wire cutting "switch high frequency" function.</p>	
P00.17	Multi-function input function selection X1	<p>0: reserved 1: Multi-speed command 5: Used as forward jog input 6: Used as reverse jog input 7: Used as a jog input (REV (X4) determines the direction)</p>	1
P00.18	Multi-function input function selection X2	<p>8: Shutdown instantly when closing action 9: Shut down instantly when disconnected 10: Disconnect, immediately stop with DC braking (regardless of PV_StopMode setting)</p>	1
P00.19	Multi-function input function selection X3	<p>11: External terminal speed increase command (only valid for main frequency P00.00, speed reduction step is specified by parameter P00.20) 12: External terminal speed reduction command (only valid for main frequency P00-00, speed reduction step is specified by parameter P00-20)</p>	1
P00.20	Multi-function input function selection X4	<p>13: External fault normally open input, "external fault" is generated at the moment of closing action 14: External fault normally closed input, "external fault" is generated at the moment of disconnection 15: External fault, closing produces "external fault" 16: External fault, disconnection produces "external fault" 17: Used as external fault reset input</p>	0

P00.21	External terminal up/down speed increment	0.0-600.0HZ	1.0HZ
P00.22	Time interval of external terminal up/down		2
P00.23	Physical quantity display proportional constant	0-999.9%	100.0%
P00.24	Display item selection after power-on	0: Display the current target frequency 1: Display motor operating frequency 2: Display motor running current 3: Display the current input AC voltage 4: Display the current bus voltage 5: Display the current output voltage 6: Display the current speed segment number SP x 7: Display the internal temperature of the inverter t xx 8: Display input signal X1-X3/output signal 9: Display user variables, namely: current output frequency X P00.23 10: Display user count value 11: Display manufacturer's temporary debugging variables	0
P00.25	Display item automatic return delay (in 10 seconds unit)	0 means no automatic return; 1-6 means return after a delay of 10-60 seconds.	1
P01.00	Prohibit motor reverse setting	0: Allow the motor to reverse; 1: Prohibit motor reverse rotation	0
P01.01	Waiting time of motor commutation		0
P01.02	Anti-overvoltage setting during deceleration (%)		140%
P01.03	Anti-overcurrent setting during acceleration (%)		140%
P01.04	Over current setting (%)		
P01.05	Overload protection setting (%)		
P01.06	Overload protection time setting (s)		
P01.07	Undervoltage protection setting (%)		
P01.08	Overvoltage protection setting (%)		160%
P01.09	When stopping, start DC braking voltage (%)		15%
P01.10	When stopping, the DC		0%

	braking voltage ends (%)		
P01.11	DC braking time during shutdown (s)		2.0
P01.12	Start frequency of DC braking at stop		
P01.13	Before starting, start DC braking voltage (%)		
P01.14	Before starting, end DC braking voltage (%)		
P01.15	DC braking time before starting		
P01.16	Direct starting initial frequency (increasing starting torque)		
P01.17	Direct start initial frequency holding time		
P01.18	Instantaneous power down frequency reduction point		
P01.19	Decrease rate of instantaneous power failure frequency		
P01.20	Restart idle time		
P01.21	Restart voltage rise time		
P02.00	Torque increase during acceleration (%)		
P02.01	Torque boost during deceleration (%)		
P02.02	Acceleration curve selection		
P02.03	Deceleration curve selection		
P02.04	Avoidance frequency 1		
P02.05	Avoidance frequency 2		
P02.06	Avoidance frequency 3		
P02.07	Avoidance frequency width		
P02.08	Window frequency1		
P02.09	Window frequency2		
P03.00	RS485 communication baud rate	0: 1200Bps 1: 2400Bps 2: 4800Bps 3: 9600Bps 4: 19200Bps 5: 38400Bps(For higher baud rate, please contact the	4

		manufacturer)	
P03.01	RS485 communication address	1-254	10
P03.02	RS485 communication format (Modbus protocol. Only supports RTU mode, not ASCII mode)	0: 8-bit data, 1 stop bit, odd parity 1: 8-bit data, 1 stop bit, even parity 2: 8-bit data, 1 stop bit, no parity 3: 8-bit data, 2 stop bits, odd parity 4: 8-bit data, 2 stop bits, even parity 5: 8-bit data, 2 stop bits, no parity	2
P03.03	Deal with RS485 communication error	0: Decelerate to stop 1: Free stop (deceleration time is invalid) 2: Immediately stop with DC braking (the deceleration time is invalid) 3: Non-stop	0
P03.04	RS485 communication error tolerance time (mS)		500
P03.05	4-20mA disconnection detection time		
P03.06	Panel potentiometer Lower limit of AD value specification	0-1023	3
P03.07	Panel potentiometer The upper limit of AD value specification	0-1023	1020
P03.08	Panel potentiometer Frequency given lower limit	0.0-600.0HZ	0.0HZ
P03.09	Panel potentiometer Upper limit of frequency given	0.0-600.0HZ	400.0HZ
P03.10	Analog input 1 Lower limit of AD value specification	0-1023, see "JP1 Short Circuit Block Configuration Table"	3
P03.11	Analog input 1 The upper limit of AD value specification	0-1023, see "JP1 Short Circuit Block Configuration Table"	1020
P03.12	Analog input 1 Frequency given lower limit	0.0-600.0HZ, see "JP1 Short Circuit Block Configuration Table"	0.0HZ
P03.13	Analog input 1 Upper limit of frequency given	0.0-600.0HZ, see "JP1 Short Circuit Block Configuration Table"	400.0HZ
P03.14	Reserved		

P03.15	Reserved		
P03.16	Reserved		
P03.17	Reserved		
P03.18	Analog output correlation setting, see "JP1 Short Circuit Block Configuration Table"		
P03.19	Analog output gain setting, see "JP1 short-circuit block configuration table"		
P04.00	Mo analog multiplier output frequency multiplier		
P04.01	Mo1 function selection		
P04.02	Mo2 function selection		
P04.03	Multifunction relay function selection	1	0: get power when fault occurs, otherwise lose power
P04.04	Multifunction relay function selection	2	1: get power while running, otherwise lose power
			2: Reserved
			3: When any frequency arrives, it will be powered, otherwise it will lose power (related to the setting of P02-10)
			4: Get power when power is off, otherwise lose power
			5: Get power at low voltage, otherwise lose power
			6: Get power when overvoltage, otherwise lose power
			7: Get power when over current, otherwise lose power
			8: Power is available at non-zero speed, otherwise power is lost*
			9: Power on when DC braking, otherwise lose power
			10: Power is applied when the torque is over, otherwise power is lost*
			11: Power is supplied when external interruption fault occurs, otherwise power is lost
			12: Get power when rotating forward, otherwise lose power
			13: Get power when reverse, otherwise lose power
			14: Power when inching, otherwise lose power
			15: Get power when accelerating, otherwise lose power
			16: Get power when decelerating, otherwise lose power
			17: Get power at constant speed, otherwise lose power
			18: When X1 is closed, power is on, otherwise power is lost

0

		19: When X2 is closed, power is on, otherwise power is off	
		20: When X3 is closed, power is on, otherwise power is off	
		21: When X4 is closed, power is on, otherwise power is off	
		22: When X5 is closed, power is on, otherwise power is off	
		23: When X6 is closed, power is on, otherwise power is off	
		24: Forward, and the bus voltage is greater than 400V, it is powered, otherwise it loses power	
		25: Reverse, and the bus voltage is greater than 400V, it is powered, otherwise it loses power	
P04.05	Multifunction relay 1 action closing delay	0-65.5s	0
P04.06	Multifunction relay 1, action disconnection delay	0-65.5s	0
P04.07	Multifunction relay 1, action closing delay	0-65.5s	0
P04.08	Multifunction relay 1, action disconnection delay	0-65.5s	0
P04.09	Locked rotor detection time	0-65.5s	1.0
P04.10	Switch (Di) sampling time	0-200ms	24
P04.11	Shutdown mode during power failure	0: Decelerate to stop 1: Free stop (deceleration time is invalid) 2: Immediate DC braking to stop (the deceleration time is invalid) 3: No shutdown when power off	0
P05.00	PID output upper limit frequency		
P05.01	PID output lower limit frequency		
P05.02	PID setting source selection		
P05.03	User preset PID given		
P05.04	PID output characteristics (positive/reverse)		
P05.05	PID input characteristics (positive/reverse)		
P05.06	PID proportional constant Kp setting 0~100.0		
P05.07	PID integral time Ti setting		

	0~100.0		
P05.08	PID differential time Td setting 0~100.0		
P05.09	PID allowable error range 0~50.0		
P05.10	PID integral upper limit		
P05.11	PID sampling time 0~600.0		
P05.12	Feedback disconnection detection time		
P06.00	Acceleration time unit: second/minute		
P06.01	1st acceleration time	0.1-6553.5	2.0
P06.02	1st deceleration time	0.1-6553.5	2.0
P06.03	2nd acceleration time	0.1-6553.5	2.0
P06.04	2nd deceleration time	0.1-6553.5	2.0
P06.05	3rd acceleration time	0.1-6553.5	2.0
P06.06	3rd deceleration time	0.1-6553.5	2.0
P06.07	4th acceleration time	0.1-6553.5	2.0
P06.08	4th deceleration time	0.1-6553.5	2.0
P06.09	5th acceleration time	0.1-6553.5	2.0
P06.10	5th deceleration time	0.1-6553.5	2.0
P06.11	6th acceleration time	0.1-6553.5	2.0
P06.12	6th deceleration time	0.1-6553.5	2.0
P06.13	7th acceleration time	0.1-6553.5	2.0
P06.14	7th deceleration time	0.1-6553.5	2.0
P06.15	8th acceleration time	0.1-6553.5	2.0
P06.16	8th deceleration time	0.1-6553.5	2.0
P06.17	Jog acceleration time	0.1-6553.5	2.0
P06.18	Jog deceleration time	0.1-6553.5	2.0
P07.00	1st section frequency setting	0.0-600.0HZ	0.0HZ
P07.01	2nd section frequency setting		100.0HZ
P07.02	3rd section frequency setting		150.0HZ
P07.03	4th section frequency setting		200.0HZ
P07.04	5th section frequency setting		250.0HZ
P07.05	6th section frequency setting		300.0HZ
P07.06	7th section frequency setting		350.0HZ
P07.07	8th section frequency setting		400.0HZ
P07.08	1st frequency source selection	0: Operation panel potentiometer given frequency (related parameters: P03.06~P03.09)	0
P07.09	2nd frequency source	1: Digital operation panel setting frequency, that is, the	2

	selection	frequency value set by parameter P00.00, directly set	
P07.10	3rd frequency source selection	by the operation panel keyboard	2
P07.11	4th frequency source selection	2: The x-section frequency P07.00~P07.07	2
P07.12	5th frequency source selection	3: External analog quantity 1 (AI1/VI1) (related parameters: P03.10~P03.13), see "JP1 short-circuit block configuration table"	2
P07.13	6th frequency source selection	4: reserved	2
P07.14	7th frequency source selection	5: Modbus Rs485 given frequency	2
P07.15	8th frequency source selection	6: User application given frequency	2
P07.16	Forward jog frequency	Other: reserved	15.0HZ
P07.17	Reverse jog frequency	0.0-600.0HZ	15.0HZ
P08.00	Automatic operation mode: direction of rotation		
P08.01	Automatic operation mode: cycle mode selection		
P08.02	Automatic running time unit: second/minute		
P08.03	Automatic operation mode 1st speed operation time		
P08.04	Automatic operation mode 2nd speed operation time		
P08.05	Automatic operation mode 3rd speed operation time		
P08.06	Automatic running mode 4th speed running time		
P08.07	Automatic running mode 5th speed running time		
P08.08	Automatic running mode 6th speed running time		
P08.09	Automatic running mode 7th speed running time		
P08.10	Automatic running mode 8th speed running time		
P09.00	Swing frequency amplitude (%)	0-200%	0
P09.01	Swing frequency step amplitude (%)	0-400%	200

P09.02	Swing frequency rise time (sec)	0.1-999.9s	6.0s
P09.03	Swing frequency fall time (sec)	0.1-999.9s	5.0s
P10.00	Counter reload value		
P10.01	Counter current value		
P10.02	Timer reload value		
P10.03	Timer current value		
P11.00	Current inverter status		
P11.01	Current output voltage		
P11.02	Current output current		
P11.03	Current output frequency		
P11.04	Current heat sink temperature		
P12.00	Motor rated current		5.0
P12.01	Motor rated voltage		220
P12.02	Number of motor pole pairs	2-100	2
P12.03	Motor no-load current (%)		20%
P12.04	Motor no-load current detection time (seconds)		10s
P12.05	Inverter rated current		5.0
P12.06	Inverter rated voltage		220
P12.07	DC bus discharge voltage%		140
P12.08	Heat sink over temperature protection point		80
P12.09	Heat sink temperature sensor configuration		1
P12.10	Abnormal reset execution waiting time		
P12.11	Fan operating mode	<p>0: Start the fan when the motor is running; after the motor stops, turn off the fan with a delay of about 1 minute;</p> <p>1: When the temperature is higher than the fan action temperature point (P12.12), the fan will be started immediately; when the temperature is lower than the fan action temperature point, the fan will be turned off after a delay of about 1 minute;</p> <p>2: Unconditionally force the fan to start;</p> <p>3: The fan does not work;</p>	1
P12.12	Cooling fan action		45

	temperature point		
P12.13	Fan detection		
P12.14	Bypass relay closed detection		
P12.15	Bypass relay delay time		
P12.16	Initial value of power-on delay timer (seconds)		
P12.17	Current sensor configuration		
P12.18	Automatic voltage regulation function selection		
P12.19	PWM frequency	2.0-15.0KHZ	8.0KHZ
P12.20	SVPWM mode	0: Three-phase asynchronous motor, 1: Two-phase asynchronous motor (single-phase motor, 90 degree phase difference, no starting capacitor)	0
P13.00	Software version number		
P13.01	Hardware version number		
P13.02	Manufacturer		
P13.03	Year of manufacture & week		
P13.04	Product ID (Combine year & week of manufacture to become UID)		
P13.05	Accumulated running time of the machine (hours)		
<p>This machine has at most 2 RS485-based MODBUS communication interfaces, and supports MODBUS RTU protocol, but does not support ASCII protocol.</p>		<p>Among them, the CN7, CN12, and CN13 sockets correspond to the first MODBUS communication interface, which is generally used to connect the LK series dedicated digital display to realize the setting and monitoring of the inverter. Of course, users can also use this interface to realize their own communication. However, the communication parameters of this communication interface are fixed as: 19200Bps, 8 data bits, 1 stop bit, no parity bit. The inverter acts as a MODBUS slave (server), and the slave address is fixed at 10.</p>	Display dedicated
		<p>CN4 and CN8 sockets correspond to the second MODBUS communication interface, which is generally used for external connection to user equipment such as PLC, HMI, PC, etc.; its communication parameters can be configured by P03.00-P03.04. The inverter acts as a MODBUS slave (server), and the slave address is also configurable.</p>	User communication

8. Fault information and troubleshooting methods

8.1 Fault information and troubleshooting methods:

Error code/fault phenomenon		Analysis of the causes of errors and solutions
Er.00 Power failure, power supply voltage is lower than 140VAC	low voltage	1、 1. Check the input power voltage to ensure that the input voltage is within the range of 150-250V. Too high input voltage will damage the inverter. 2、 2. With large inertia load, the deceleration time setting value is too small.
Er.01 The power supply voltage is higher than 290VAC, and the internal bus voltage is too high	Voltage too high	3、 3. Inaccurate detection of the power supply voltage by the inverter makes the display voltage of the inverter inconsistent with the actual power supply voltage, which requires maintenance. 4、 When there is a large inertia load, such an error occurs when the motor decelerates, please consider installing a suitable external braking resistor.
Er.02	The current is too large	When the motor is running, overcurrent occurs (the actual output current is too large), please check whether the motor is short-circuited, the connection method is correct, and the mechanical load is too large. Otherwise, maintenance is required.
Er.03	External PWM circuit error	When the motor is running, there is an error in the internal PWM circuit of the CPU. Turn off the power for about 1 minute, and then retry the operation. If this phenomenon occurs again, maintenance is required.
Er.04	IPM alarm (short circuit)	1、 When the motor is running, the internal power unit module of the inverter has an error: 2、 1. The acceleration and deceleration time settings are too short; 3、 2. The inverter is overcurrent and overheated, please check whether the motor is short-circuited or the mechanical load is too large; 4、 3. The input voltage is too high/low, or the input voltage fluctuates greatly; 5、 4. The power of the inverter and the motor do not match, or the star/delta wiring is wrong; 6、 5. The DC braking parameters (P01.09-P01.17) are set improperly; 7、 6. VF parameters (P00.04-P00.12) are set improperly; 8、 7. The cooling fan is damaged or blocked, and the inverter has poor heat dissipation; 9、 The gate drive voltage of the power component is too high or too low, requiring maintenance.
Er.05	External fault signal is input	When the external fault signal input is valid, the motor stops and displays this code, reset can be eliminated, no maintenance is required
Er.06	Internal data storage error	There is an error in the internal data parameter storage of the inverter. Turn off the power for about 1 minute, and then test the

		operation. If this phenomenon occurs again, maintenance is required.
Er.07	Over temperature	<p>1、 The internal temperature of the inverter is too high (above 65 degrees), please check:</p> <p>2、 1. When the motor is running, whether the cooling fan stops rotating (Note: After the motor stops rotating for 1 minute, the cooling fan of some versions of the inverter automatically stops rotating to extend the life of the fan);</p> <p>3、 2. Please check whether the motor is short-circuited and the motor load is too large;</p> <p>4、 Whether the heat conduction between the internal module of the inverter and the heat sink is good.</p>
Er.08	NTC temperature measurement error	The internal temperature detection circuit of the inverter is faulty or the temperature detection sensor is defective, and needs to be repaired.。
Er.09		
Er.10	Power down prompt	1、 Please check the input power voltage to ensure that the input voltage is within the range;
Er.11	RS485 communication is disconnected and error occurs, and the machine stops.	Related to parameters P03.03, P03.04
Er.12	Parameter error	
Er.13		
Er.14		
Er.15	Motor overheated	

9. Modbus holding register address-inverter parameter correspondence table

Modbus holding register address-inverter parameter correspondence table				
	Holding register address (hexadecimal)		Corresponding inverter parameters	Macro definition/description
Power-down save area (in EEPROM)	0x0000		P00.00	
	0x0001		P00.01	
	
	0x0100		P01.00	
	0x0101		P01.01	
	
	0x0200		P02.00	
	0x0201		P02.01	
	
	0x0D00		P13.00	
	0x0D01		P13.01	
	

Note:

1. Modbus protocol. Only supports RTU mode, not ASCII mode.

2. The corresponding law of Modbus holding register address and inverter parameters: the high 8-bit address (hexadecimal) of the holding register corresponds to the group index of the inverter parameter; the low 8-bit address corresponds to the number in the parameter group. For example, the hexadecimal holding register address 0x0c14 corresponds to the inverter parameter P12.20 (group 12, parameter 20, PWM mode).

Modbus holding register address-inverter application function correspondence table

usRegHoldingBuf[]	Modbus holding register address	Modbus485 operation command	Function Description		
0	0x2000(8192)	bit 1:0	b00: No function	struct sAPP_CMD example: ModbusAppCmd	
			b01: shutdown command		
			b10: start command		
			b11: Jog command		
			bit 3:2		Reserved
			bit 5:4		b00: No function
	b01: Forward command				
	b10: reverse command				

			b11: change direction	
		bit 7:6	b00: No function	
			b01: reset an error flag	
			b10: reset all error flags	
			b11:reserved	
1	0x2001(8193)	Modbus485 frequency command	x0.1HZ	
2	0x2002(8194)	Modbus485 acceleration time	x0.1s	
3	0x2003(8195)	Modbus485 deceleration time	x0.1s	
4	0x2004(8196)			
5	0x2005(8197)			
6	8198			
7	8199			
8	8200	ErrorFlag	Error code	Read only
9	8201	Ms	Inverter internal state	
10	8202	AimFreq	Target frequency	
11	8203	RunFreq	Output frequency	
12	8204	OutCurrent	Output current	
13	8205	RunVolt	The output voltage	
14	8206	MainLineVolt	Bus voltage	
15	8207	SpSeg	Multi-stage speed	
16	8208	AccDecFlag		
17	8209	AccTime	Current acceleration time	
18	8210	DecTime	Current deceleration time	
19	8211	AdvAin1	AD value of external analog quantity 1 (10bit)	
20	8212	AdvAin2	AD value of external analog quantity 2 (10bit)	
21	8213		X1-X8 state	
22	8214	Flash_reg		LED_OBJ_MAP_ADD R
23	8215	Dot_reg		
24	8216	DecodeReg		
25	8217	LedBuf[0]		
26	8218	LedBuf[1]		
27	8219	LedBuf[2]		
28	8220	LedBuf[3]		

29	8221	LedBuf[4]		
30	8222	LedBuf[5]		
31	8223	LedBuf[6]		
32	8224	LedBuf[7]		
33	8225	Unique_IDSum	Feature code of CPU unique ID	
34	8226	MakeKey/BreakKey		KEY_OBJ_MAP_ADD R
35	8227	KeyMap		
36	8228	Adv1	AD value of panel potentiometer 1 (10bit)	
37	8229	Adv2	AD value of panel potentiometer 2 (10bit)	
38	8230	Reversed		
39	8231	Islegal	Version flag	
40	8232			
41	8233			
42	8234			SprttterRunCmd
43	8235			eSpatterStatus
44	8236			SpatterPosition
45	8237			
46	8238			
47	8239			
48	8240			
49	8241			
50	8242			
51	8243			
52	8244			
53	8245			
54	8246			
55	8247			
56	8248			
57	8249			
58	8250			
59	8251			
60	8252			struct sAPP_CMD example: SplcAppCmd
61	8253			
62	8254			
63	8255			
64	8256			struct sAPP_CMD example: SysAppCmd
65	8257			struct sAPP_CMD example: ExAppCmd

66	8258			
67	8259			
68	8260			
69	8261			
70	8262			
71	8263			
72	8264			
73	8265			
74	8266			
75	8267			

10. External terminal two or three wire control motor wiring

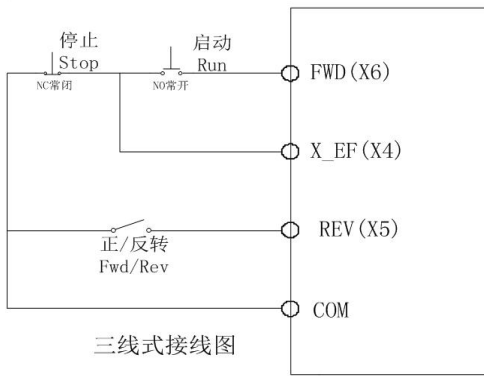

参数设置：
 P00. 1 设置为1-->由外部端子操纵电机，操作面板STOP键有效；
 P00. 16 设置为2-->EF (X4), REV (X5), FWD (X6), 自保持).
 三线式控制电机运行

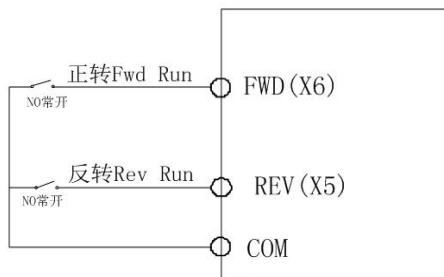

参数设置：
 P00. 1 设置为1-->由外部端子操纵电机，操作面板STOP键有效；
 P00. 16 设置为0-->FWD (X6) 是正向运行命令，REV (X5) 是反向运行命令
 二线式控制电机运行

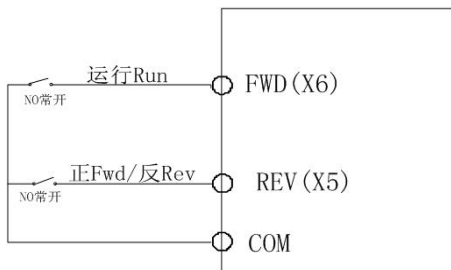

参数设置：
 P00. 1 设置为1-->由外部端子操纵电机，操作面板STOP键有效；
 P00. 16 设置为1-->REV (X5) 决定方向：开为正转，闭为反转；
 FWD (X6) 是启动命令：开则停机，闭则运行. 二线式控制电机运行

11. Multi-speed command-frequency section-parameter item correspondence table

Multi-speed input X3	Multi-speed input X2	Multi-speed input X1	Operating frequency section/corresponding parameters	
open circuit	open circuit	open circuit	1st section frequency/P07.00	
open circuit	open circuit	closure	2nd section frequency/P07.01	High
open circuit	closure	open circuit	3rd section frequency/P07.02	Medium
open circuit	closure	closure	4th section frequency/P07.03	
closure	open circuit	open circuit	5th section frequency/P07.04	Low
closure	open circuit	closure	6th section frequency/P07.05	
closure	closure	open circuit	7th section frequency/P07.06	
closure	closure	closure	8th section frequency/P07.07	

12. Toggle switch configuration table

1.2 Push up 3.4 Push down to 10V	1.2.3.4 Push down to 5v
-------------------------------------	-------------------------

13. Facilities selection configuration

13.1 Braking resistor configuration:

specification	Brake resistor configuration		Dedicated motor KW
	W	Ω	
0.75KW-220V/110V	80W	220 Ω	0.75KW
1.5KW-220V/110V	150W	220 Ω	1.5KW
2.2KW-220V/110V	250W	200 Ω	2.2KW

Remarks: The frequency inverter needs to install a brake unit to achieve rapid braking

Note: ①Please select the resistance and frequency of use specified by our company;
 ②If you use brake resistors and brake modules that are not provided by our company and cause the inverter or other equipment to be damaged by mistake, our company will not take any responsibility;

③The installation of braking resistor must consider the safety of the environment, flammability, and the distance from the inverter is 100mm;

④If you want to change the resistance and power, please contact your local dealer;

⑤If you need a braking resistor, the braking resistor needs to be ordered separately.

Please contact your local dealer for details.

⑥For machinery with large inertia, please increase the capacity of the braking resistor.

For details, please contact your local dealer.

14. Customer feedback suggestions